

Solar Systems Design and Sizing

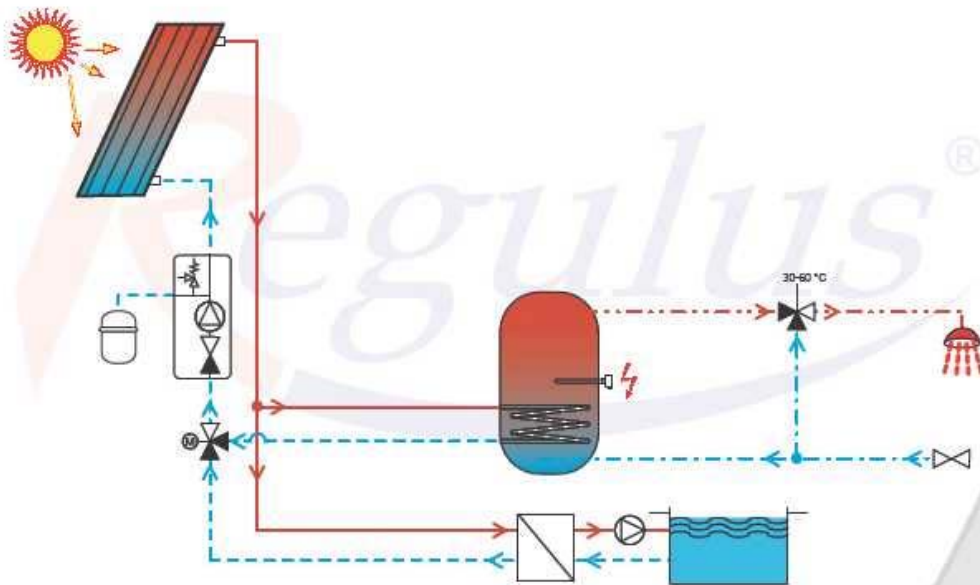

Regulus[®]

Solar Systems – Design and Sizing

Contents:

1. Selecting the right collector
2. Collector surface sizing, orientation
3. Heat storage sizing
4. Selecting a solar system regulation
5. Circulation pump
6. Pressure in solar systems, safety valve and expansion tank
7. Removing air
8. Piping, insulation
9. Connection scheme examples

The Sun supplies an immense quantity of energy to the Earth but we do not utilize it and produce heat from other sources. Since the prices of traditional energy sources keep rising (and will grow faster year by year), the attention of not only scientists but also of general public turns to the alternative energy sources that can be utilized almost free of charge.

High purchase costs for alternative energy appliances gradually go down being utilized more currently, while the costs for traditional energies keep growing. Thanks to that, large-scale utilizing alternative energies is growing very fast.

The Sun can be used as a heat source for heating-water or DHW heating, or for direct production of electricity by means of photovoltaic cells. While the efficiency of photovoltaic cells reaches some 15% and necessary investments for 1 kW of output are very high, and without subsidized electricity buyout the investment will not pay off at all, in the water heating systems the investment for a comparable output is 10 times lower and pays off well even without subsidies.

The only problem of the Sun as an energy source is the sunshine fluctuation and uneven distribution of its energy during a year. While in the summer the average annual solar energy received by 1 sqm of the Earth's surface in middle Europe reaches some 160-170 kWh, in the winter it is only about 20 kWh.

This scheme is a precise contrary to what can be effectively used for heating – in the winter, when the need for heat is big, the energy supply is low and its utilizing poor because of the worse efficiency of solar collectors at low outdoor temperatures. And since no suitable system has been found yet that would enable accumulating the easily gained summer energy and using it in the winter for heating (the classical heat accumulation into water for heating an average house would require a water volume of the size of a small lake), the energy gained is currently accumulated for 1-1.5 of a house daily consumption, and if there is no sunshine, water is heated by other sources (usually electric coils or a gas boiler).

For this reason, the heat from solar energy is mainly used for DHW heating (its need is almost even all year round), or for seasonal pool heating. Collectors can be used for additional heating mostly in the transitional period of spring-autumn but even then the purchase cost of such collectors is substantially higher than that of collectors intended for DHW heating. The most advantageous combination is thus a system of

winter additional heating – summer pool heating, then the large collector surface installed is used all year round.

A design of a suitable solar system can be divided into the following steps:

1. Selecting the right collector

A solar collector shall fulfill two important functions – to absorb as much sunshine as possible (absorptance reaches as much as 95% for the best collectors), to transfer effectively the gained heat into a heat carrier, and first of all, to lose only as little heat as possible through its own heat losses. While absorption reaches a good level for most collectors on the market (even a black-painted barrel shows a good solar absorption ability), there are big differences namely in the collector heat losses. The losses may occur by heat dissipation through the insulation and case of the collector itself, or by convection (through the air above the absorber and then by dissipation through the collector glass) and by radiation of the absorber surface itself. Just these thermal losses make a good share of the total thermal loss of a collector and so much attention is paid to it.

ABSORPTANCE OF VARIOUS COLLECTOR SURFACES

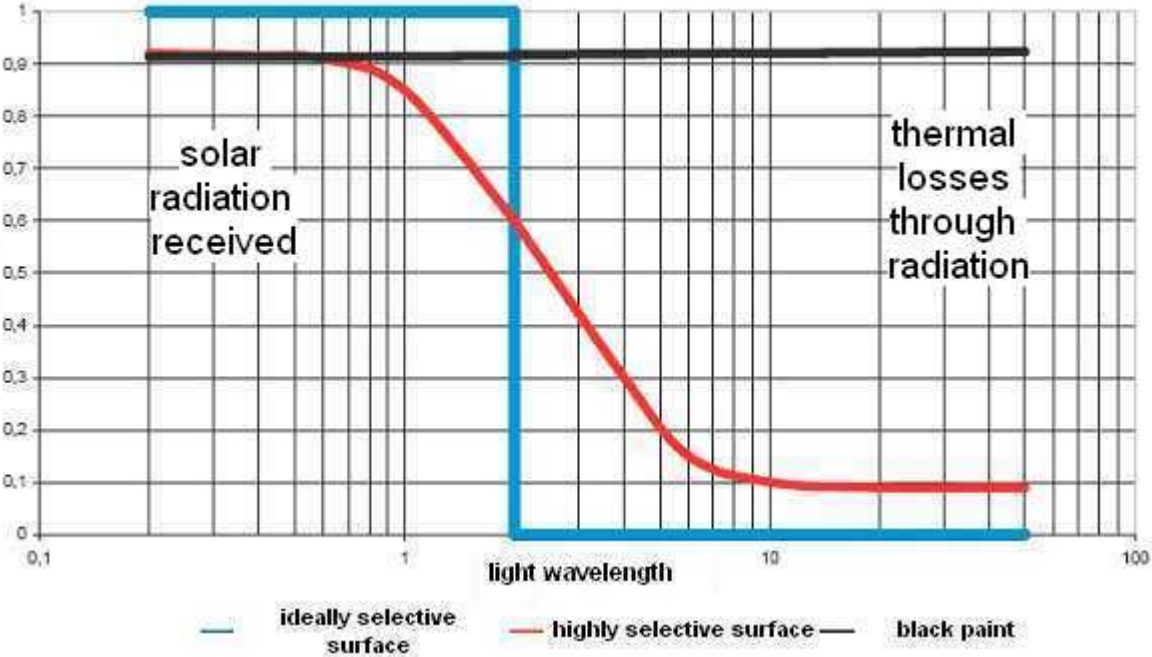

When collectors are operated during hot days and with low temperature of the heated fluid, thermal losses are very low and differences among various types of collectors are also very small. Thermal losses will become significant only when there is a bigger temperature difference between the collector fluid and ambient air – i.e. when heating the fluid to higher temperatures or in the winter when ambient temperatures are low. Of course, during cloudy days the heat losses represent a higher share in the total heat balance of a collector. That's why it is so important to select carefully the right collector, esp. when intended for additional heating or all-year pool heating

or preparing DHW; for a seasonal pool heating the collector parameters play a less important role. A collector of high thermal losses may supply no energy at all during the winter because its thermal loss will be as high as the energy it gains from the sunshine.

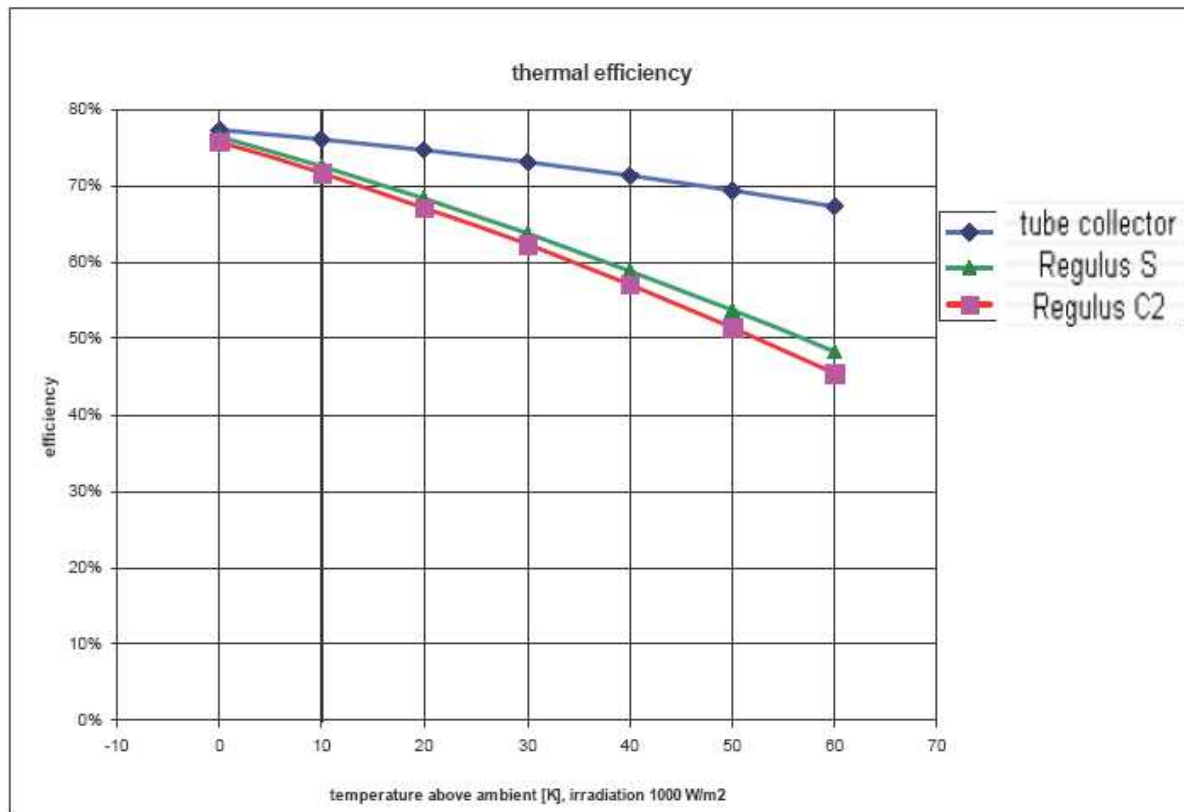

Collector characteristics – efficiency / temperature difference

The glass in flat collectors plays also an important role. Partly it should have as high penetrability as possible to solar radiation, partly it should have good insulation properties (the whole absorber front side is not covered by insulation and so rather big losses through heat convection can be limited only by lower heat conductivity of the glass). However, using a double glazing is not suitable because the intensity of the incoming radiation is substantially weakened by passing two glasses. The glass should be also resistant to breaking (e.g. by hail). These conditions are met by so called solar glass, produced specially for usage in solar collectors. Even a better solution is called solar prismatic glass, it has microscopic ridges on its inner side that diffuse light and amend thus energy gains, esp. when the sunshine comes from a low angle.

FLAT COLLECTOR

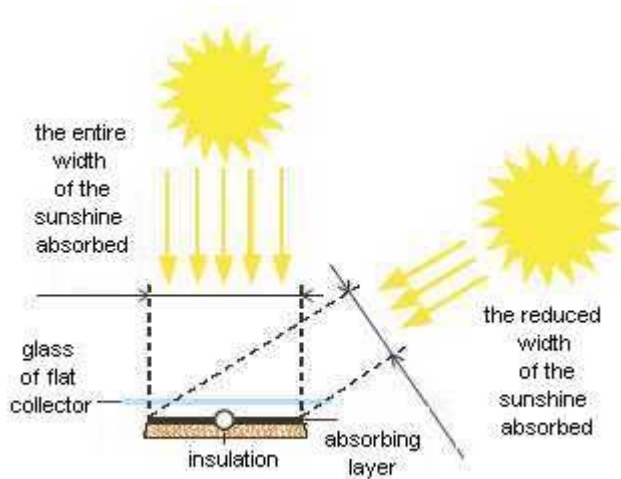

TUBE COLLECTOR

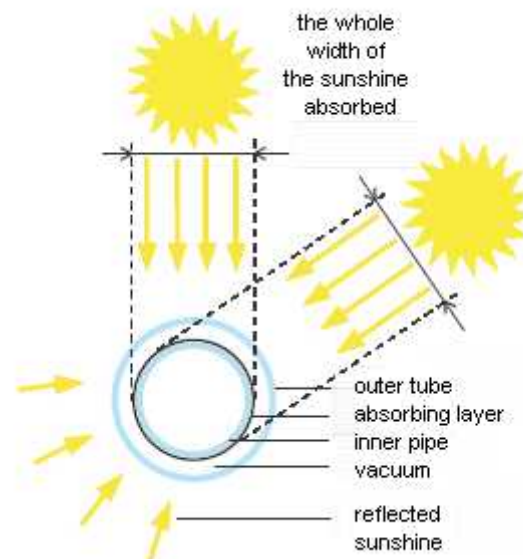

Comparison of flat and tube collectors

So, selecting the right collector is a matter of when we wish to use the collector. For seasonal pool heating, cheaper collectors of worse thermal properties will be sufficient, for prolonging a bathing season to the spring and autumn, collectors for all-year operation shall be used (black chrome or Sunselect surface), as well as in case when all-year solar-heated DHW and additional heating is desired. For better energy gains or for operation under extreme temperatures, the best solution is using tube collectors, esp. the versions with many tubes without mirrors bring energy gains even from diffuse radiation, i.e. during cloudy periods (diffuse radiation is reflected only very little by mirrors).

2. Collector surface sizing, orientation

A calculation of a collector surface size always comes out from the heat quantity needed and the period in which this need shall be covered. The energy needed is then compared to the average quantity of solar energy received by 1 sqm in the period in question, decreased according to the solar system efficiency. The result is the size of collector surface needed, possibly increased by an index in case of adversely oriented collectors, which is finally re-calculated to the number of collectors needed.

An example of collector surface sizing for DHW:

-establishing the heat need

if the total daily need of hot sanitary water is known, the heat required to heat it up can be calculated by the popular equation $Q=mc(T_2-T_1)$. Usually 50 l of domestic hot

water per person daily is presumed, and if the incoming cold water temperature is 10°C and warmed water 45°C, the calculated resulting value is 2 kWh per person.

-establishing the collector size

solar collectors are usually calculated to cover 100% of DHW need in the period between April and August. The chart of average energy gains in the individual months shows that the least heat available is in April - 4 kWh/sqm daily. If the average efficiency of the whole solar system in this period can be considered about 50%, the average energy of 2 kWh/sqm daily is available for water heating. That is exactly as much as the considered consumption for one person per day. **So, the size of a solar collector needed is 1 sqm per one family member.** If a total yearly balance of energy needed for DHW warming is calculated, it comes out that under these presumptions the solar system covers about 60% of the yearly heat need.

If we wish to increase this share and e.g. double the collector size, then the energy utilized in the summer months (April-August) will be the same because the energy needed is already supplied by the originally sized system. Increased utilization will be noticeable only in the remaining months with little sunshine, and so the percentage of utilization of all-year-round operation will rise only a little, reaching some 75% of annual need for heat.

On the contrary, in case of undersizing the collector by 30% against the calculated surface, the coverage of the yearly heat need sinks to 50%. It is obvious from these numbers that neither modest increase, nor decrease in the heat-transfer surface against the calculated value will change the energy balance of the solar system substantially. The reason is that in the summer the increased collector surface will not bring higher heat quantity because it cannot be utilized.

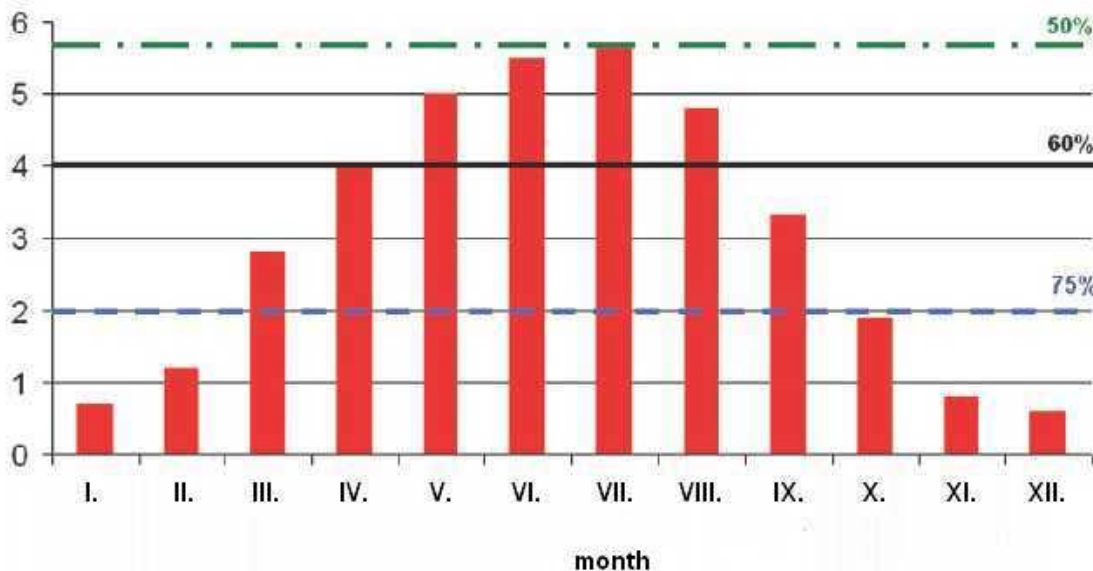

average daily energy for 1 sqm (kWh/sqm)

Correction of collector surface area:

- depending on the energy received in various regions:

The calculations were done for the solar irradiance of 1100 kWh/sqm.

- depending on the orientation of collectors towards the South and their inclination

The orientation of a collector with respect to the South and its inclination (the angle from a horizontal plane) represents another factor influencing the total energy balance.

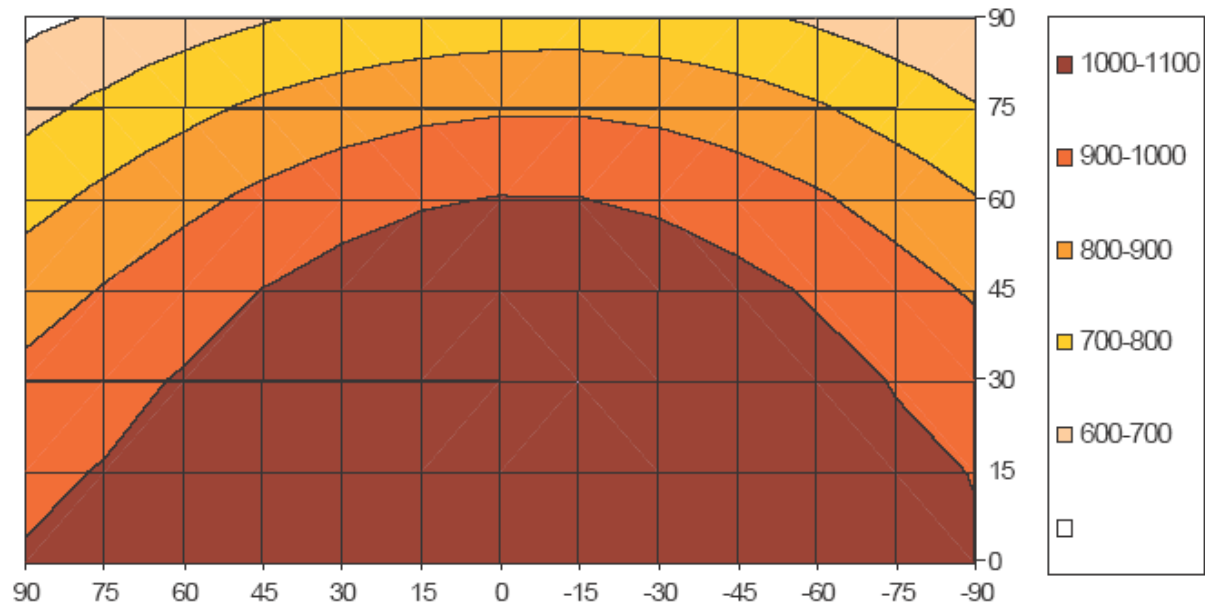

Annual solar irradiance on variously oriented (horizontal axis) and variously inclined (vertical axis) planes in the Czech Republic [kWh/sqm]

3. Sizing the heat accumulating tank

There are two basic types of heat accumulating tanks, depending on their function: domestic hot water tanks and accumulation tanks for heating water.

When sizing a DHW tank or an accumulation tank, usually a size for 1-1.5-day heat consumption is used. For DHW tanks, sizing comes out from the number of persons to be served, the usual size of a tank for calculations is 0-70 liters/person. Due to an instable energy supply for the Sun it is advisable to over-size the tank a little.

4. Selecting a solar regulation system

A regulation influences principally the right operation of a solar system and ensures its safe and unmanned operation. In order to regulate simple solar systems for heating DHW or a pool, simple differential regulators are used that switch a solar circulation pump through the temperature difference between collectors and a tank (or a pool heat exchanger). Such regulators are e.g. SR 1.1 - analog differential regulator with an adjustable difference and a night cooling function, and DeltaSol BS/3 a digital differential regulator with an adjustable switch-on and switch-off difference, inbuilt thermostat function and safety functions.

For more complex solar systems the differential solar regulators DeltaSol BS Pro and DeltaSol ES are used. These are digital regulators capable of controlling systems of more branches (e.g. an East-West system scheme with 2 collector fields), or systems with more loads (e.g. a combined DHW and a pool heating).

For solar systems with additional heating so called intelligent regulators for heating systems should be used. as e.g. the IR09 regulator. This is an intelligent regulator that controls differentially the primary circuit of a solar system. Thanks to its time programs it can regulate heating according to preset temperatures and heating curves, and the during days of little sunshine it switch a further source (a gas boiler, electric boiler...).

5. Selecting a circulation pump

A circulation pump transports heat-carrying fluid between a collector and a heat exchanger (heat storage). Current calculations for a circulation pump in a closed heating system with forced circulation can be used also here. For current applications it is usual to use a pump integrated into a so called pump group that includes also further safety elements (safety valve) and components ensuring proper operation of a solar system (a check valve, flow regulator etc.). In these pump groups mostly such pumps are integrated that are suitable for solar systems, operating with propylene-glycol based heat transfer fluid. These pumps (e.g. Wilo ST20/6 in the FlowCon S pump group) offer both a sufficient flow and head for most solar systems of one and two loads, used in family houses. If the solar application is bigger and more complicated, the circulation pump must ensure the right flow rate of the heat carrier through a collector. For collectors with so called tube-grid absorbers (KPC, KTU and ETC collectors) the recommended flow is 1-2 l/min. and the flow-rate values add up in case of more collectors, e.g. for 3 collectors the flow rate through a system should be $3 \times 2 \text{ l/min} = 6 \text{ l/min}$. For collectors with a so called meander-shaped absorber (KPS collectors), the recommended flow is 1.5-1.8 l/min. If the system consists of max. 5 collectors, these can be connected in series and their flow rates do not add up.

6. Pressure in solar systems, selecting a safety valve and an expansion tank

Safety valves are always a part of pump groups. If a pump group is not used, a solar system must be equipped with a safety valve with opening pressure of 600 kPa (6 bar) and resistant to higher temperatures (mostly up to 160°C).

The pressure in a solar system is calculated from the equation $p = 1.3 + (0.1 \times h)$ where p is the pressure in a solar system (in bar), h is the height (vertical distance) from the pressure gauge to the middle of the solar panels (in meters). The result shows the pressure to be set at the pressure gauge in the pump group.

An expansion tank serves for compensating changes in the expansivity of the heat transfer fluid, avoiding its unnecessary losses, and for maintaining the pressure in a solar system within the specified range. An expansion tank in solar systems must be thus sized so as to compensate the temperature difference between the minimum temperature in the winter (even -20°C) and maximum temperature in the summer, and to accommodate the entire volume of collector liquid in case that the heat transfer fluid evaporates from collectors. In forced-circulation solar systems principally only expansion tanks with a diaphragm of propylene-glycol resistant material. The preset pressure in the expansion tank shall be decreased by 0.5 bar against the calculated system pressure: $p_{\text{exp}} = p - 0.5 \text{ (bar)}$.

7. Air vent

Select the air venting point at the highest point of the system. It is recommended to amend the air vent with a local pipe widening that calms down the stream and helps in good separating bubbles from the fluid. For an efficient removal of bubbles from the system it is advisable to fit a pump group with an air separator. The only

exception is represented by smaller solar systems with KPS or ETC collectors where no air vent is needed at the highest point of the system, if the size of the connecting pipes is selected so that the liquid flow speed is higher than 0.4 m/s. Then any present bubbles are taken by the stream and caught in an air separator, placed in a pump group. If automatic air vents are used, these must be closed after air venting the whole system. Under operation conditions with no heat consumption, the fluid in collectors turn to steam that could escape through an open air vent and cause unnecessary losses of the heat transfer fluid.

8. Distribution system, piping and insulation

Pipes of the solar system must be fitted with thermal insulation e.g. of AEROFLEX type, so that thermal dissipation from the pipes does not deteriorate a total efficiency of the solar system. The thermal insulation should be resistant to temperatures up to 160°C, for outdoor piping also a UV protection is essential as well as non-deliquescence of the material. Primary circuit piping must be resistant up to 160°C and 6 bar pressure. In no case plastic tubes can be used for inlet/outlet piping as they do not meet the requirements for solar systems (thermal and mechanical stress). It is recommended to realize the whole piping of copper pipes connected by soldering. Pressed-on fittings may be used only if they resist the heat transfer fluid, the pressure (6 bar) and the temperature (stagnation temperature of the collector).

The connecting piping from collectors should be lead the shortest way, for this reason the Tichelmann coil for balanced supply to collector fields is thus made principally on the return piping to the collectors. Pipes for collectors can be lead through existing chimneys, ventilation shafts or grooves in a wall, preferably in the interior. In order to prevent high thermal losses through convection, open shafts shall be properly sealed. Also thermal dilatation shall be remembered and pipes fitted with compensators or other compensation elements. Piping shall be connected to the house earthing.

The size of the inlet and outlet piping can be calculated from an empirical equation:

$$d \geq \sqrt{0,35 \cdot V}$$

d ... pipe diameter [mm]
V ... flow rate through solar collectors [l/h]

The equation comes out of a presumption that the flow speed in the piping will not exceed 1 m/s. The nearest higher nominal values shall be selected than the calculated value of the min. pipe diameter needed.

9. Connection examples

DHW heating

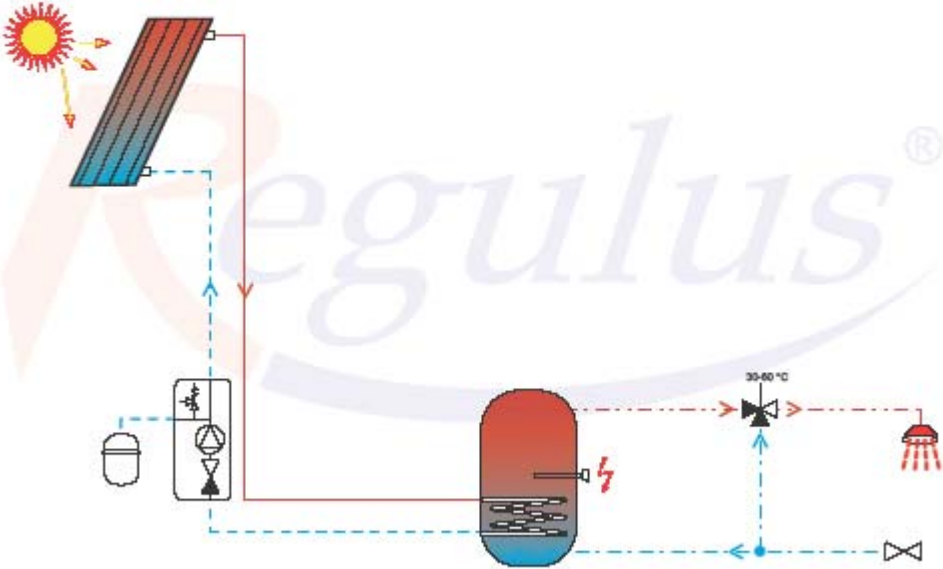

DHW pre-heating

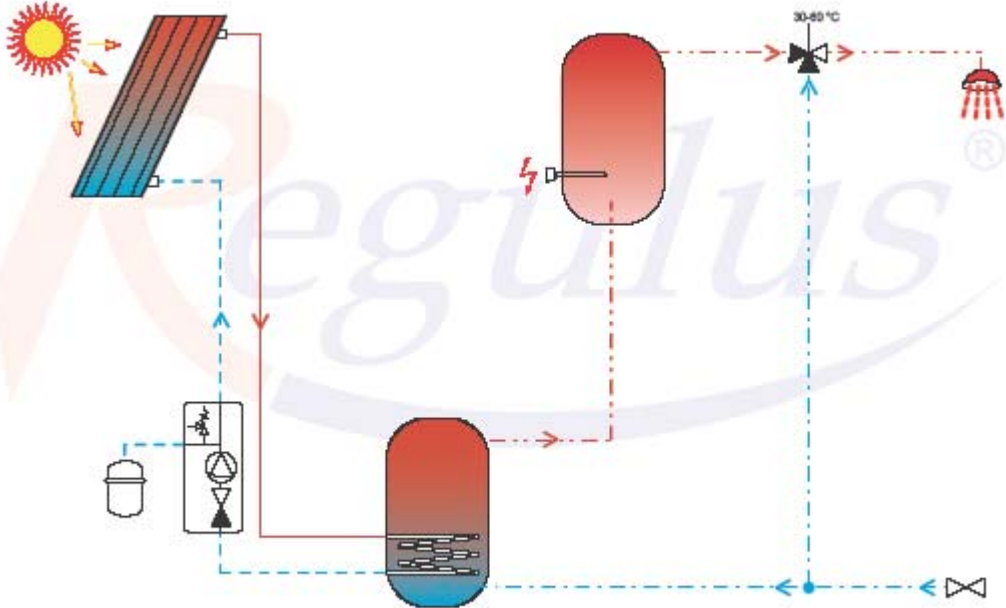

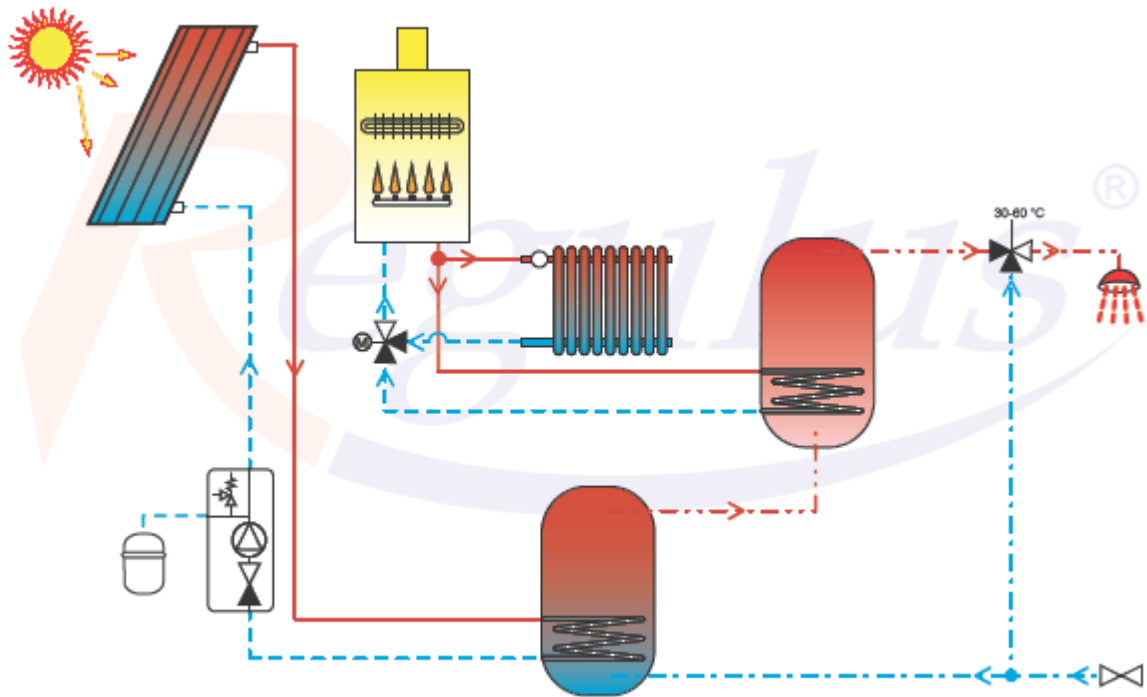

DHW heating - East/West orientation system

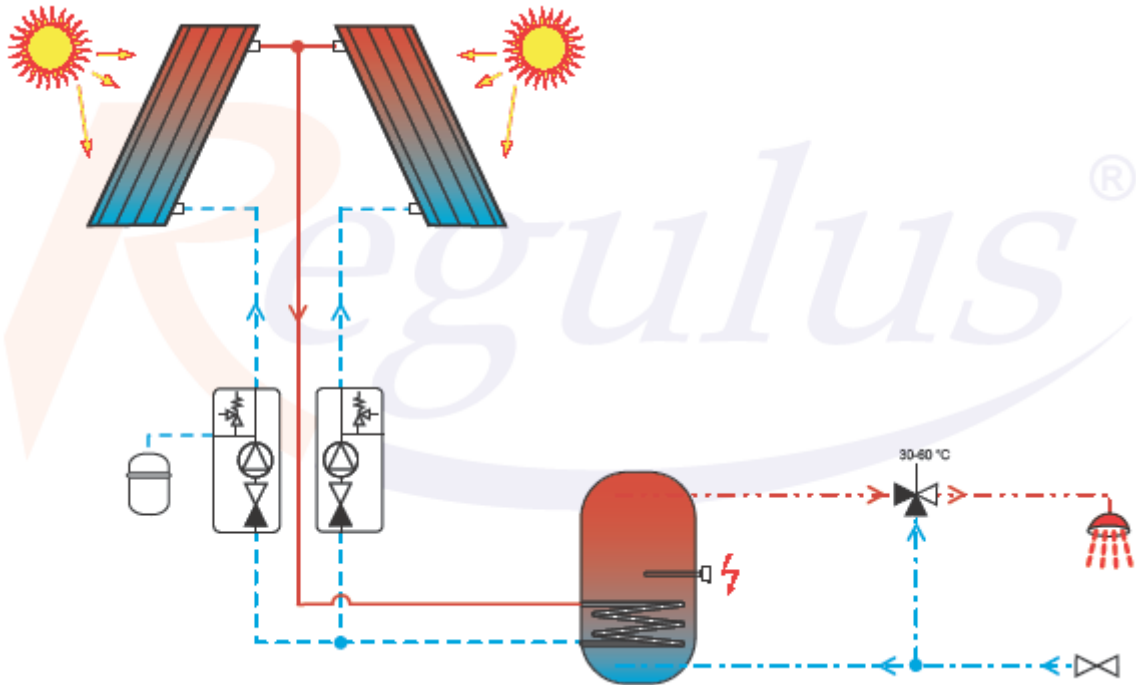

DHW heating in a tank with 2 heating coils

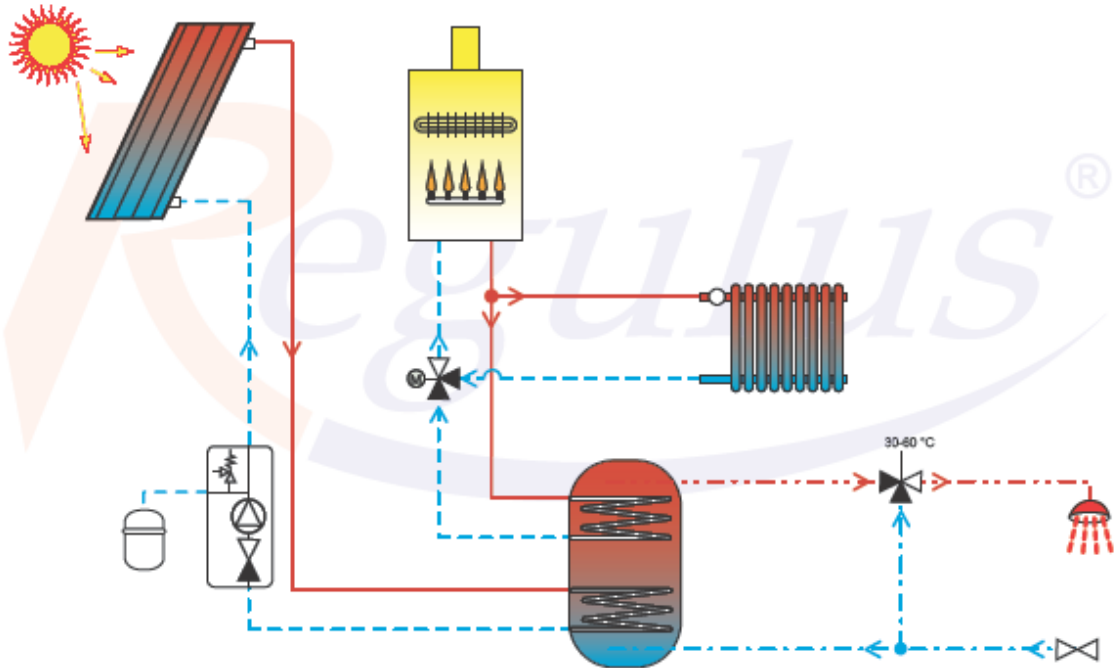

Combined DHW- and pool heating

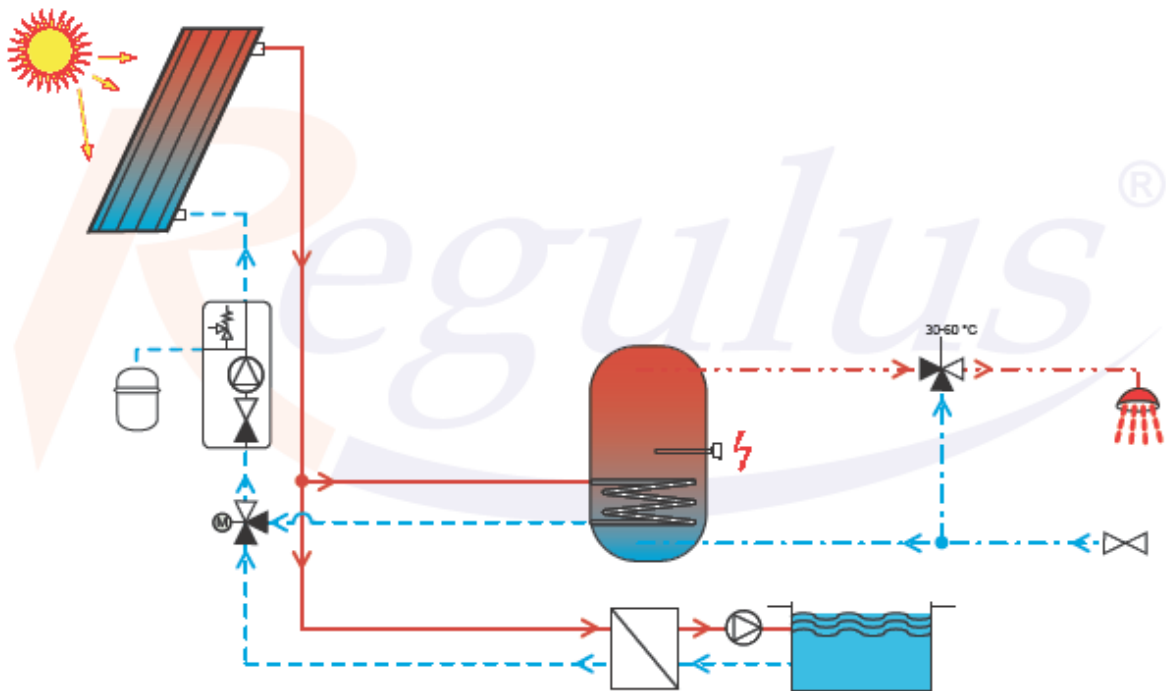

Systems with additional heating

